

## R-433



### Twin Pilot 4-Way Valve

#### Features:

- Indicator shows valve in shaded position
- Micro gap construction - snap action and no blow by
- Dual pilots eliminate shuttle valve
- Balanced design allows speed control at exhausts

#### Performance:

**Flow:** 9 scfm @ 100 psig  
**Pilot Pressure Minimum:** 40 psig  
**Temperature:** 32 to 180°F  
**Working Pressure:** 0 to 150 psig

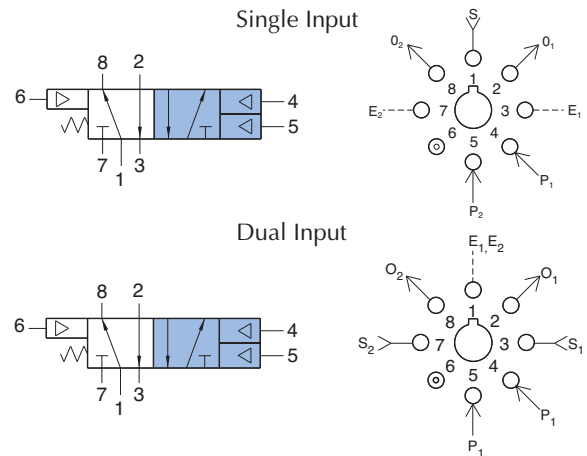

#### Description:

R-433 is a 5 ported, 4-way valve, with spring return and dual pilots.

## R-434



### Twin Pilot 4-Way Valve

#### Features:

- Indicator shows valve in shaded position
- Micro gap construction - snap action and no blow by
- Dual pilots eliminate shuttle valve
- Balanced design allows speed control at exhausts

#### Performance:

**Flow:** 9 scfm @ 100 psig  
**Pilot Pressure Minimum:** 20 psig  
**Temperature:** 32 to 180°F  
**Working Pressure:** 0 to 150 psig

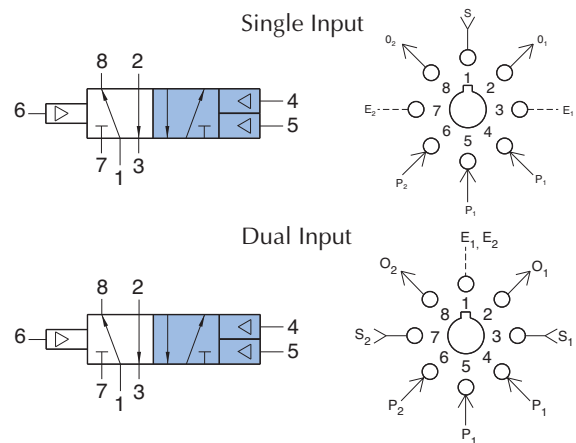

#### Description:

R-434 is a 5 ported, 4-way, two position, double piloted valve.